

# Typical Standard Size Elevator Cabs - SEE 5-3 RULE

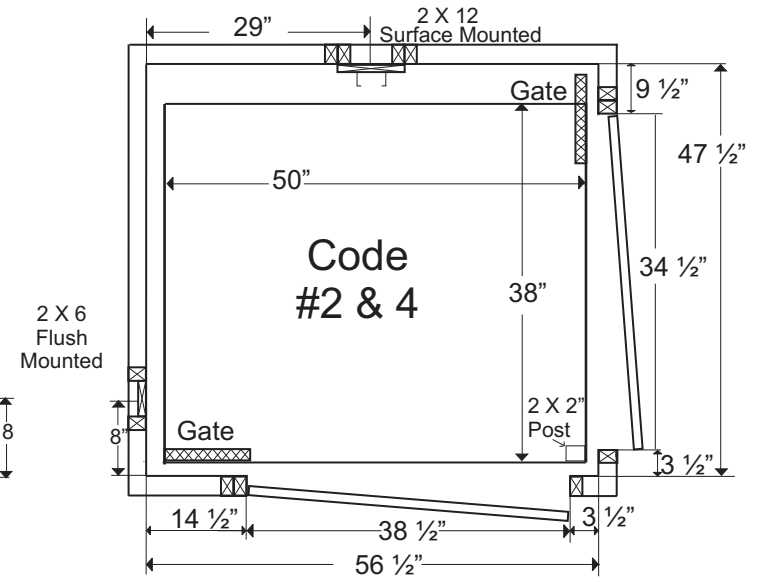

**Please Note:**  
**Drop Slab 8" Below Finish Grade Floor**

- All Dimensions are Rough
- Drawings Not to Scale
- Typical Shafts, as Shown, May be Changed to Suit Job Conditions

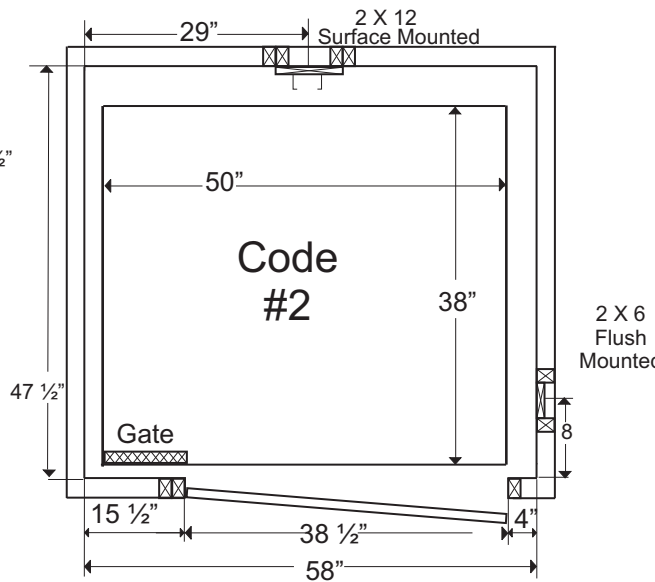
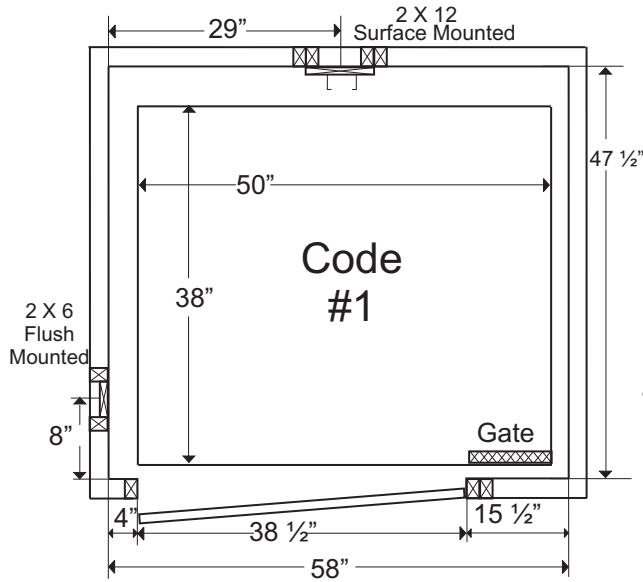

ANY WALL HOUSING AN ENTRY DOOR SHOULD BE 2X4 CONSTRUCTION. CALL FOR ALTERNATIVES.

Phone: 713-961-1940  
 Fax: 713-466-8844  
 Email: mselev@sbcglobal.net

